

## Introduction to Internet Mail

**Philip Hazel**

University of Cambridge Computing Service

### Mail agents

- MUA = Mail User Agent
- Interacts directly with the end user  
Pine, MH, Elm, mutt, mail, Eudora, Mulberry, Pegasus, Netscape, Outlook, ...
- Multiple MUAs on one system – end user choice
- MTA = Mail Transfer Agent
- Receives and delivers messages  
Sendmail, Smail, MMDF, Charon, Exim, qmail, Postfix, ...
- One MTA per system – sysadmin choice

## Message format (1)

From: Philip Hazel <ph10@cus.cam.ac.uk>  
To: Julius Caesar <julius@ancient-rome.net>  
Cc: Mark Anthony <MarkA@cleo.co.uk>  
Subject: How Internet mail works

Julius,

I'm going to be running a course on ...

- Format was originally defined by RFC 822 in 1982
- Now superseded by RFC 2822 (published 2001)
- Message consists of
  - Header lines – some have a well-defined syntax
  - A blank line – terminates the end of the header
  - Body lines
- Notice that a message is defined in terms of *lines*

## Message format (2)

- An email address consists of a *local part* and a *domain*

    julus@ancient-rome.net  
    ↑          ↑  
local part  domain

- A basic message body is unstructured ASCII text
- Other RFCs (MIME, 2045) add additional header lines that define structure for the body
- MIME supports attachments of various kinds and in various encodings
- Creating/decoding attachments is the MUA's job

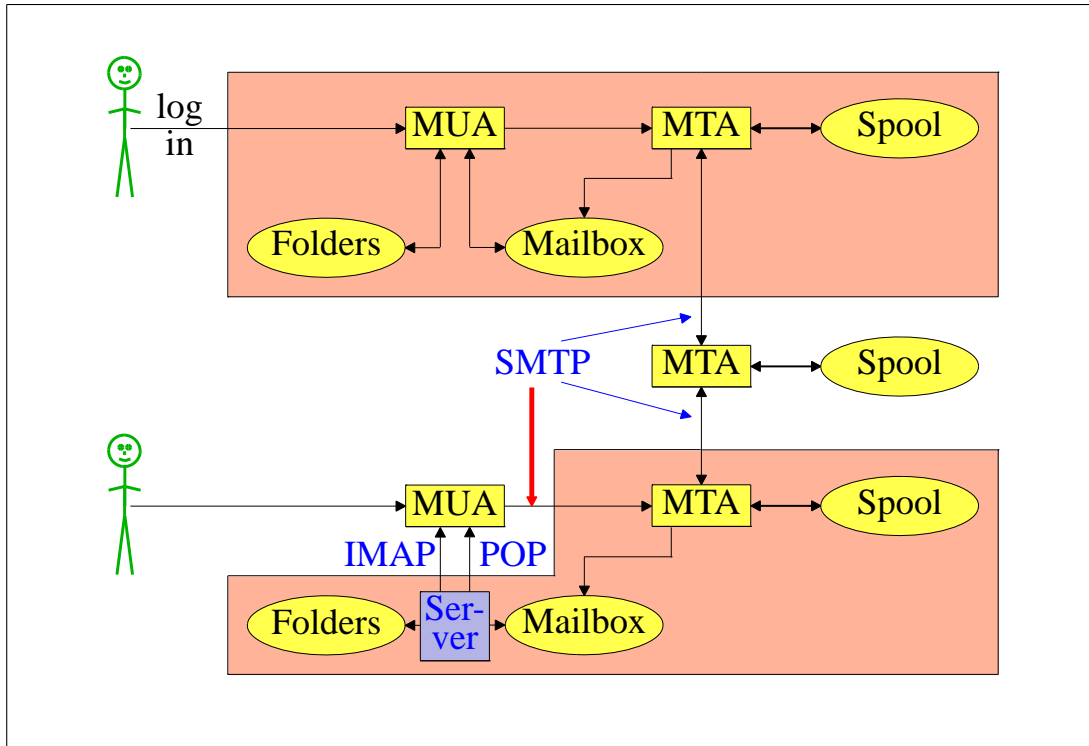

## Authenticating senders

- Embedded MUA uses inter-process call to send to MTA
  - May use pipe, file, or internal SMTP over a pipe
  - MTA know the identity of the sender
  - Normally inserts *Sender:* header if it differs from *From:*
- Freestanding MUA uses SMTP to send mail
  - MTA cannot easily distinguish local/remote clients
  - No authentication in basic SMTP protocol
  - AUTH command in extended SMTP
  - Use of security additions (TLS/SSL)
  - MUA can point at any MTA whatsoever
  - Need for relay control
  - Host and network blocks

## A message in transit (1)

- Headers added by the MUA before sending

```
From: Philip Hazel <ph10@cus.cam.ac.uk>  
To: Julius Caesar <julius@ancient-rome.net>  
Cc: Mark Anthony <MarkA@cleo.co.uk>  
Subject: How Internet mail works
```

```
Date: Mon, 10 May 2004 11:29:24 +0100 (BST)  
Message-ID: <Pine.SOL.3.96.990117111343.  
19032A-100000@taurus.cus.cam.ac.uk>  
MIME-Version: 1.0  
Content-Type: TEXT/PLAIN; charset=US-ASCII
```

```
Julius,  
I'm going to be running a course on ...
```

## A message in transit (2)

- Headers added by MTAs

```
Received: from taurus.cus.cam.ac.uk  
([192.168.34.54] ident=exim)  
by mauve.csi.cam.ac.uk with esmtp  
(Exim 4.30) id 101qxX-00011X-Ab;  
Mon, 10 May 2004 11:50:39 +0100  
Received: from ph10 (helo=localhost)  
by taurus.cus.cam.ac.uk with local-smtp  
(Exim 4.31) id 101qin-0005PB-2c;  
Mon, 10 May 2004 11:50:25 +0100
```

```
From: Philip Hazel <ph10@cus.cam.ac.uk>  
To: Julius Caesar <julius@ancient-rome.net>  
Cc: Mark Anthony <MarkA@cleo.co.uk>  
Subject: How Internet mail works  
Date: Mon, 10 May 2004 11:29:24 +0100 (BST)  
...
```

## A message in transit (3)

- A message is transmitted with an *envelope*:  
MAIL FROM:<ph10@cus.cam.ac.uk>  
RCPT TO:<julius@ancient-rome.net>
- The envelope is separate from the RFC 2822 message
- Envelope (RFC 2821) fields need not be the same as the header (RFC 2822) fields
- MTAs are (mainly) concerned with envelopes  
Just like the Post Office...
- Error (“bounce”) messages have null senders  
MAIL FROM:<>

## An SMTP session (1)

```
telnet relay.ancient-rome.net 25
220 relay.ancient-rome.net ESMTP Exim ...
EHLO taurus.cus.cam.ac.uk
250-relay.ancient-rome.net ...
250-SIZE 10485760
250-PIPELINING
250 HELP
MAIL FROM:<ph10@cus.cam.ac.uk>
250 OK
RCPT TO:<julius@ancient-rome.net>
250 Accepted
DATA
354 Enter message, ending with "."
Received: from ...
```

*(continued on next slide)*

## An SMTP session (2)

```
From: ...  
To: ...  
etc...  
.  
250 OK id=10sPdr-00034H-4B  
QUIT  
221 relay.ancient-rome.net closing connec...
```

### SMTP return codes

2xx OK  
3xx send more data  
4xx temporary failure  
5xx permanent failure

## Email forgery

- It is trivial to forge unencrypted, unsigned mail
  - This is an inevitable consequence when the sender and recipient hosts are independent
  - It is less trivial to forge email really well!
  - Most SPAM contains forged senders and forged header lines
  - Be alert for forgery when investigating
  - and ...
- ▶ **Never send automatic SPAM or virus warnings!** ◀

## The Domain Name Service

- The DNS is a worldwide, distributed database
- DNS servers are called *name servers*
- There are multiple servers for each DNS *zone*
- Secondary servers are preferably off-site
- Records in the DNS are keyed by type and domain name
- Root servers are at the base of the hierarchy
- Caching is used to improve performance
- Each record has a time-to-live field

## Use of the DNS for email (1)

- Three DNS record types are used for routing mail
- *Mail eXchange* (MX) records map mail domains to host names, and provide a list of hosts, with preferences

```
hermes.cam.ac.uk. MX 5 green.csi.cam.ac.uk.  
MX 7 ppsw3.csi.cam.ac.uk.  
MX 7 ppsw4.csi.cam.ac.uk.
```
- *Address* (A) records map host names to IPv4 addresses

```
green.csi.cam.ac.uk. A 131.111.8.57  
ppsw3.csi.cam.ac.uk. A 131.111.8.38  
ppsw4.csi.cam.ac.uk. A 131.111.8.44
```
- IPv6 addresses use AAAA (“quad A”) records

```
ahost.csi.cam.ac.uk. AAAA 2001:630:200:...
```

## Use of the DNS for email (2)

- MX records were added to the DNS after its initial deployment
- Backwards compatibility rule  
If no MX records found, look for an address record, and if found, treat as an MX with 0 preference
- MX records were invented for gateways to other mail systems, but are now heavily used for handing generic (e.g. corporate) mail domains

## Other DNS records

- The PTR record type maps IP addresses to names
- The IP address is inverted, then looked up in **in-addr.arpa**  
`57.8.111.131.in-addr.arpa.`  
`PTR green.csi.cam.ac.uk.`
- PTR and address records do not have to be one-to-one  
`ppsw4.csi.cam.ac.uk. A 131.111.8.33`  
`33.8.111.131.in-addr.arpa.`  
`PTR lilac.csi.cam.ac.uk.`
- CNAME records provide a general aliasing facility  
`pelican.cam.ac.uk.`  
`CNAME redshank.csx.cam.ac.uk.`



## DNS lookup tools

- *host* is easy to use for simple queries

```
host demon.net
host 192.168.34.135
host -t mx demon.net
```

- *nslookup* is more widely available, but is more verbose in both input and output

```
nslookup bt.net
nslookup 192.168.34.135
nslookup -querytype=mx bt.net
```

- *dig* is the ultimate nitty-gritty tool

```
dig bt.net
dig -x 192.168.34.135
dig energis.net mx
```

## DNS mysteries

- Sometime primary and secondary name servers get out of step
- When mystified, check for server disagreement  
A second argument for **host** specifies a name server

```
host -t ns xxx.ac.uk
xxx.ac.uk NS mentor.xxx.ac.uk
xxx.ac.uk NS ns0.ja.net

host hermes.xxx.ac.uk mentor.xxx.ac.uk
hermes.xxx.ac.uk A 192.168.1.3

host hermes.xxx.ac.uk ns0.ja.net
hermes.xxx.ac.uk has no A record at
ns0.ja.net (Authoritative answer)
```

## Common DNS errors

- Final dots missing on RHS host names in MX records
- MX records point to aliases instead of canonical names  
This should work, but is inefficient and deprecated
- MX records point to non-existent hosts
- MX records contain IP addresses instead of host names on the right-hand side  
Unfortunately some MTAs accept this  
Also, some name server software conspires to support this
- MX records do not contain a preference value
- Some broken name servers give a server error when asked for a non-existent MX record

## Routing a message

- Process locally handled addresses  
Alias lists  
Forwarding files  
Local mailboxes
- Recognize special remote addresses  
For example, those for local client hosts
- Look up MX records for remote addresses
- If self in the list, ignore all MX records with preferences greater than or equal to own preference  
This logic is for secondary MX servers
- For each remaining MX record, get the host's IP address(es)

## Delivering a message

- Perform local delivery
- For each remote delivery
  - Try to connect to each remote host until one succeeds
  - If it accepts or permanently rejects the message, that's it
- After temporary failures, try again at a later time
- Time out after deferring too many times
- Addresses are often sorted to avoid sending multiple copies of the same message
  - The RFCs recommend single copies with multiple recipients
  - Sometimes single copies are necessary

## Checking incoming senders

- A lot of messages are sent with bad envelope senders
  - Misconfigured mail software
  - Unregistered domains
  - Misconfigured name servers
  - Forgeries – probably now the biggest cause nowadays
- Many MTAs check the domain of the sender address
- It is harder to check the local part
  - A reverse SMTP “callout” is needed
  - Uses more resources and can be quite slow
- Bounce messages have no envelope sender; no check is possible

## Checking incoming recipients

- Some MTAs check each local recipient during the SMTP transaction
  - Errors are handled by the *sending* MTA
  - The receiving MTA avoids problems with bad senders
- Other MTAs accept messages without checking, and look at the recipients later
  - Errors are handled by the *receiving* MTA
  - More detailed error messages can be generated ...
  - ... but not necessarily delivered
- The current proliferation of forged senders has made the first approach much more popular

## Relay control

- Incoming: From any host to specific domains
  - Example: incoming gateway or backup MTA
- Outgoing: From specific hosts to anywhere
  - Example: outgoing gateway on local network
- From SMTP-authenticated hosts to anywhere
  - Example: travelling employee or ISP customer connected to a remote network
- Encryption can be used for password protection during authentication
- Authentication can also be done using certificates

## Policy controls on incoming mail

- Block known miscreant hosts and networks  
Realtime Blackhole List (RBL), Dial-up list (DUL), and many more
- Block known miscreant senders  
Not as effective as it once was for SPAM
- Refuse malformed messages
- Refuse virus-laden messages
- Recognize junk mail  
Discard  
Annotate